



Dando Drilling International

Dando Sonic SDC375

A multipurpose sonic drilling rig capable of continuously collecting large diameter undisturbed samples at much higher rates than conventional drilling methods. Its compact and powerful design, featuring the industry leading Sonikor 50K rotary head, offers great flexibility for a range of drilling applications including mineral, water, geotechnical and GSHP.



Sonic SDC375 Features



Features Sonic Drill Corp's patented Sonikor 50K head, renowned for its robust construction, clean, compact design and proven reliability.



Automatic single rod handler with 180 degree wrist, for enhanced safety of the operator.

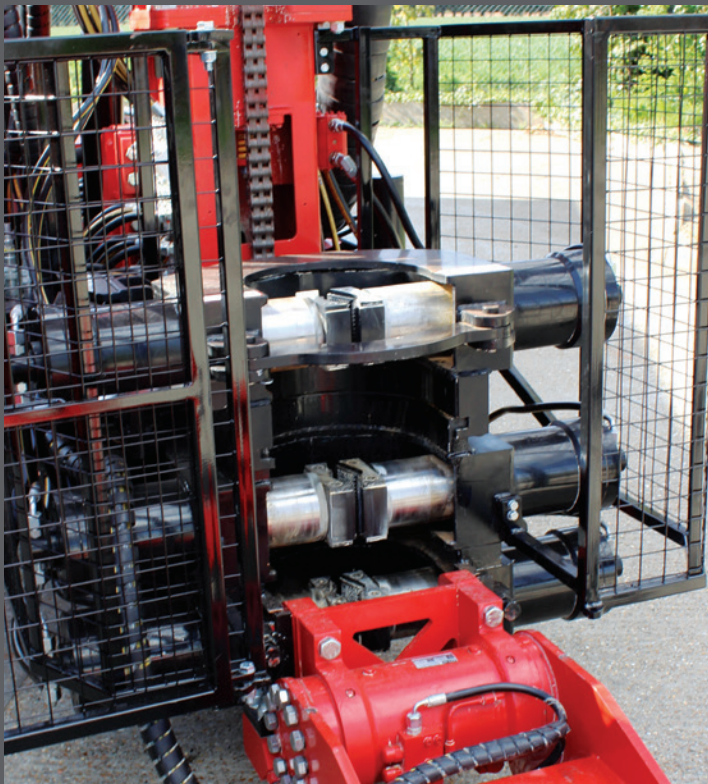

Multiple break-out clamp options available, with safety cage feature.



Uncomplicated and user friendly swing out control panel with ergonomic layout and LED console lighting.



Sonic SDC375 Features



Compact crawler mounted design ideal for maneuvering through tight areas of difficult access. The rig is available with multiple track options as well as truck mounting.



Fits inside a standard container for easy transportation.



Mast dump allows drilling to be conducted at angles of up to 45 degrees.



Sonic SDC375 Specification

Carrier	Crawler mounted as standard with multiple bolt-on track options
	Truck mounted available as an option
	Radio remote tracking with manual override or pilot hydraulic umbilical chest pack
Levelling Jacks	4 jack legs with automatic counter balance valve
Deck Engine	John Deere 6090- 350hp
	CAT C7.1 Tier 4 Final- 250hp
	Other engine options available
Drill Mast	Single box construction
	4.2m head travel. Other lengths available
	Hydraulic cylinder/chain driven system. Auto tensioned
	Pullback: 10,000kgf
Mast Dump	Allows for angle drilling to 45 degrees c/w support struts.
Main Winch	Maximum single line pull: 2000kgf
	Maximum speed: 40m/minute
	Drum capacity: 65m of 13mm wire rope
Water Pump	FMC L1122 - 284 lpm - 1000 psi (other optional water pump sizes available)
Hydraulic System	Hydraulic power circuit based on load sensing hydraulic pumps and proportional control valves
	525L hydraulic reservoir
	Twin electric hydraulic oil cooler
Sonic Head	Sonicor 50K rotary head with side shift and tilt frame
	Sonic output force: 50,000 lbs
	Sonic frequency: 0-150 Hz
	Rotation: 0-140 rpm
	Rotation torque: 7000 ft-lb @ 0-140 rpm
Control Console	Swing out control panel
	Ergonomic configuration
	Direct hydraulic control valves with minimal electric controls
	Pilot control valves
Clamps	As standard: Double acting hydraulic make up and break out clamp with clamping diameter of 60-250mm
	Other options available, including double acting breakout table to 340mm or triple breakout clamps

Sonic SDC375 Specification

Options

Automatic single rod handler with 180 degree wrist
Lockable waterproof deck boxes x 2
Mast lighting package
Auxiliary service lines with electrical, air and hydraulic quick disconnects
Mast mounted automatic SPT trip hammer (63.5kg) - Complete with electronic blow counter
Larger tooling and wireline winches available
Cold weather winterisation package

Dimensions

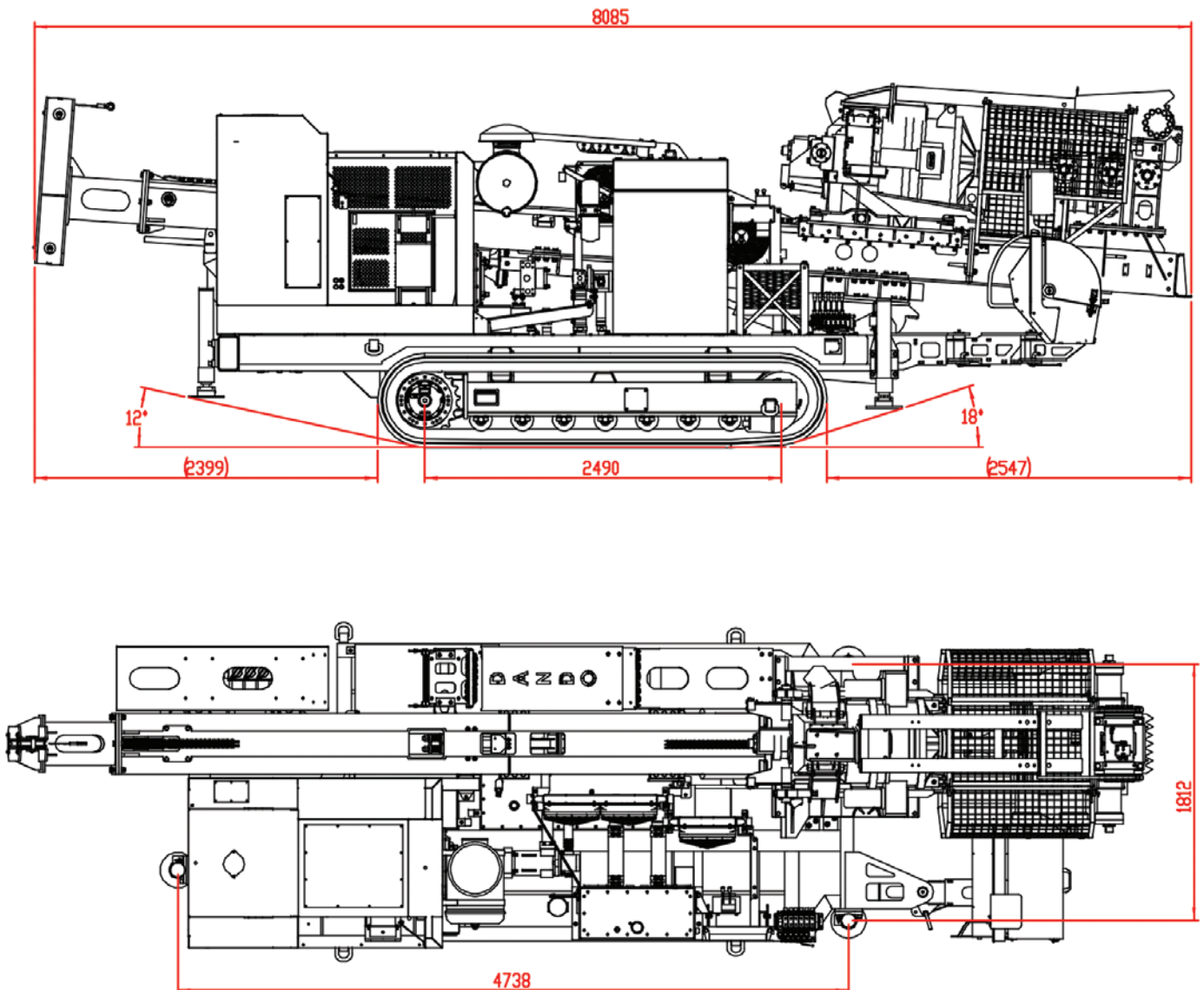

Weight: 14,000kg

*depending on specification

